

ERGONOMIX

— Be at the best level —

Ergonomix is an adjustable worktop. It allows everyone to work at a height that suits them, depending on their size or the task. Ergonomix helps reduce the risk of musculoskeletal injury, a leading cause of work absence.

EASY TO USE

Manual operation of the crank makes it possible to raise or lower the platform according to the user's needs. There is no electrical connection required.

ERGONOMIC

After adjusting the height, the crank can be folded under the worktop, avoiding the risk of snagging or shocks.

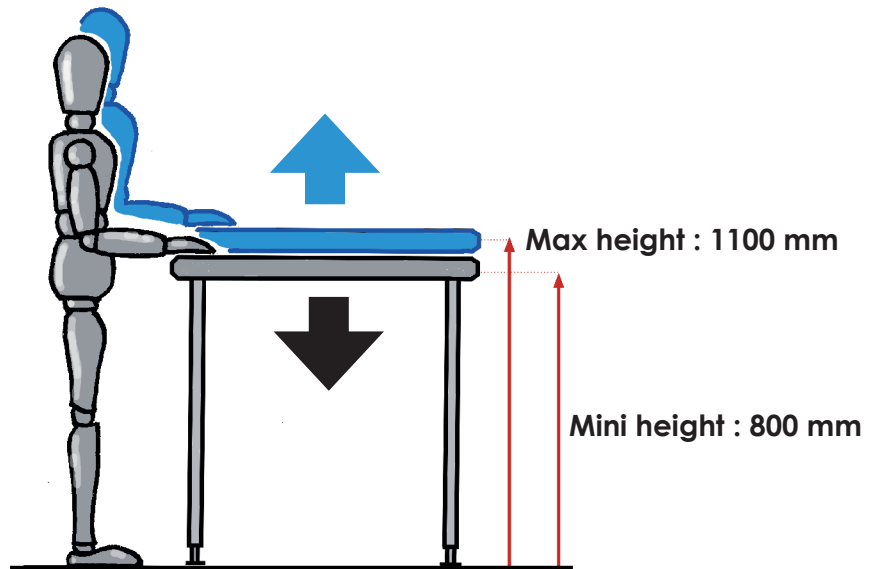

STABLE AND SOLID

The robust pump and cylinder guidance system combine with the welded and reinforced table frame, to ensure perfect worktop stability during ascent, descent and use.

WIDE RANGE

Ergonomix, **40 available models** : free-standing worktop, worktop with upstand, with or without lower shelf and with or without wheels. Ergonomix can also be equipped with an optional drawer.



READY TO USE

The worktop is delivered ready to use. The product is already pre-assembled and checked in our factory.

Just remove the packaging, clean the surface of the worktop and it's ready to use immediately by staff.



ERGONOMIX

TECHNICAL FEATURES

Food grade stainless steel construction with a chromium content greater than 17.5%. Width 700 mm.

Top :

- 1.5 mm thickness.
- lined by laminated panel with aluminum under side tables
- central worktop with rounded front and rear edges.
- or worktop with rear upstand height 100 mm and rounded front edge. Sliding pads attached to the back of the upstand for protection of the wall during ascent and descent.

Feet :

- square stainless steel legs - 40 x 40 mm.
- hydraulic system (stroke 0 - 300 mm) controlled by a retractable crank.
- 4 adjustable jacks for balancing.
- or 4 stainless steel wheels Ø 125 mm with 2 brakes.

Options :

- stainless steel drawer, ref. 809 564
- removable stainless steel shelf 1.2 mm thickness. Hookable on the spacers.

FREE-STANDING

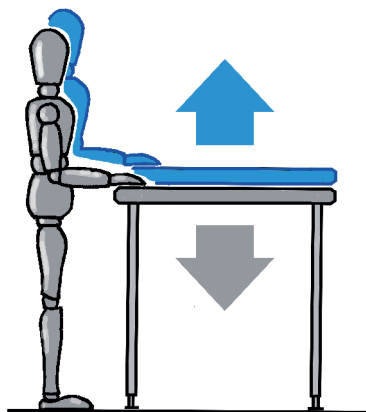
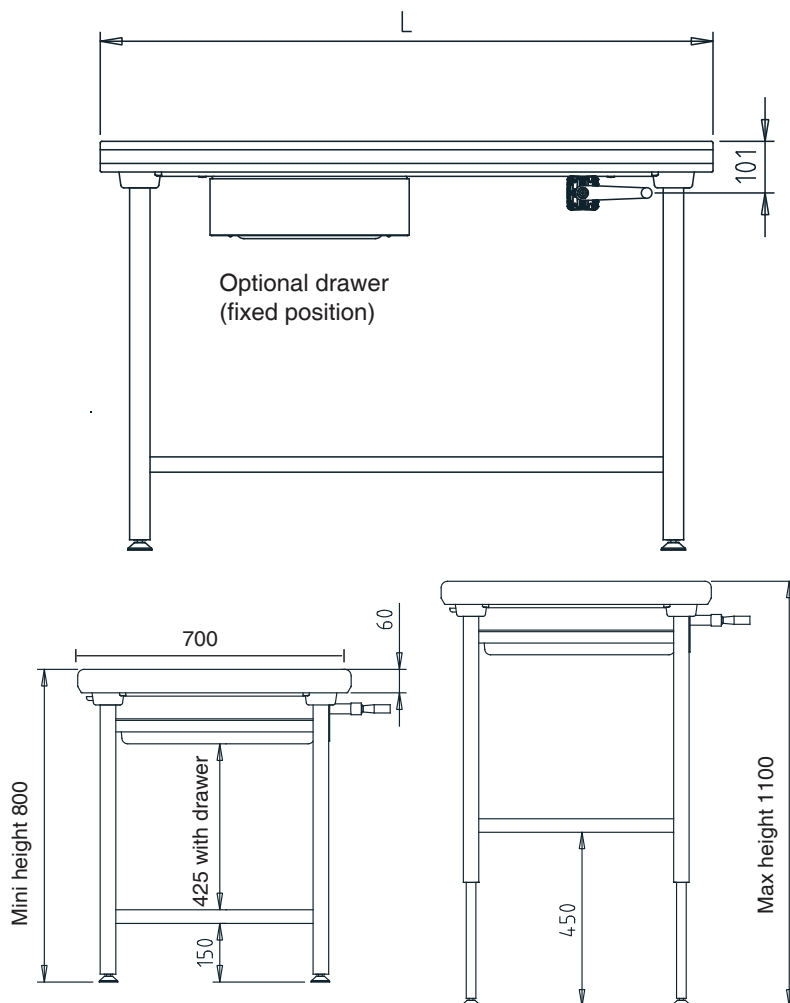

ERGONOMIX
— Be at the best level —

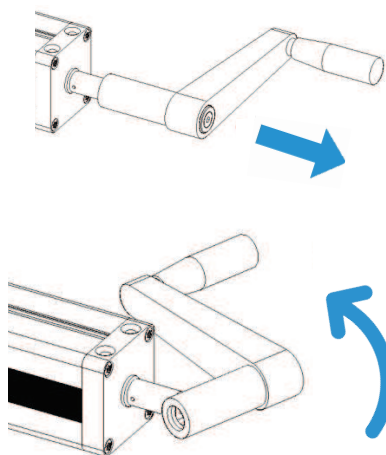

Folding handle after use



Length (mm)	Free-standing tables		Free-standing tables with shelf		Tables with upstand		Tables with upstand with shelf	
	on feet	on wheels	on feet	on wheels	on feet	on wheels	on feet	on wheels
1000	404 701	414 701	424 701	464 701	404 711	414 711	424 711	464 711
1200	404 702	414 702	424 702	464 702	404 712	414 712	424 712	464 712
1400	404 703	414 703	424 703	464 703	404 713	414 713	424 713	464 713
1600	404 705	414 705	424 705	464 705	404 715	414 715	424 715	464 715
1800	404 706	414 706	424 706	464 706	404 716	414 716	424 716	464 716

Flash on the video ergonomix

