

**Sorting units to be placed against a wall.** Without rear cladding (for the same cladding, see option ref. 702 053). Stainless steel construction. Top 1,5 mm thick with 2 waste disposal holes Ø 190 - 280 mm with grey rubber surround, one cut-out with 3 copolyester GN 1/3 cutlery containers, 150 mm deep supplied with a recess for baskets with diamond point base and discharge. Choice of cladding for sides and front from the 15 shades for our self-service units and cafeteria trolleys. Self-service type tray rest. Bin bag holder surface. Hinged door under tray rest for access to bin bags. Overall width 1015 mm. **Sorting unit on wheels Ø 125 mm and with drain pan.** The sorting units are supplied with a lifting / folding ramp on stainless steel consoles to facilitate access to the bag holder.



707 541



727 541

Description	Overall dim. L x W x h (mm)	Ref.
Sorting unit for "children"	2100 x 700 x 720	707 540
Sorting unit for "adults"	2100 x 700 x 900	707 541
Sorting unit for "children" on wheels	 2100 x 700 x 720	717 540
Sorting unit for "adults" on wheels	 2100 x 700 x 900	717 541
Sorting unit for "children" with drain pan	2100 x 700 x 720	727 540
Sorting unit for "adults" with drain pan	2100 x 700 x 900	727 541
Sorting unit for "children" with drain pan on wheels	 2100 x 700 x 720	737 540
Sorting unit for "adults" with drain pan on wheels	 2100 x 700 x 900	737 541

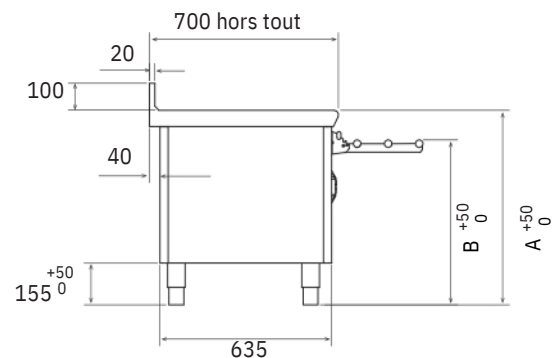
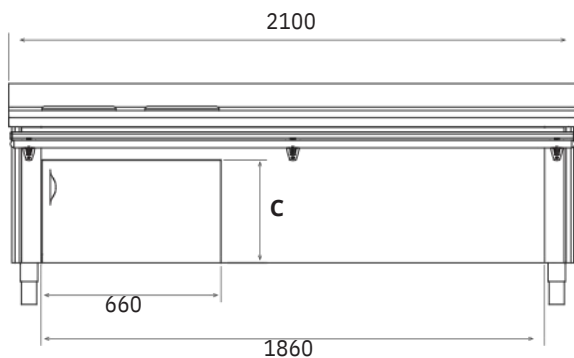

- **Sturdy** : The tray rest is fixed to the structure of the units.
- **Complete stations** : Designed to clear plates, store glass and cutlery.
- **Ergonomic** : Tray rest. Suited to the size of the children.
- **Eye-catching**: The cladding blends in with the decorative finish of the self-service unit or the room.
- **Compact** : Take up a minimum amount of space.

Quotations	A	B	C
Sorting unit for "children"	720	610	398
Sorting unit for "adultes"	900	790	578

### Drop-down and lift-up tray rest



703 497  
Down tray rest



Lift up tray rest

# PRE-SORTING UNITS

Stainless steel construction, 900 mm high. Top 1,5 mm thick and 2, 3 or 4 waste disposal holes Ø 190 - 280 mm with grey rubber surround. Rounded edge. Choice of cladding for sides and front from the 15 shades in the Eurodekor by Egger range. Self-service type tray rest. Supplied with 800 mm high mobile bag holders without lid, placed at the back of the unit. Safety stand to avoid any risk of the cabinet tipping over with a narrow base.



707 536



## ERGONOMIC :

- With tray rest
- The standard bag holders on the central units facilitate waste discharge
- Customizable cladding



## PRACTICAL BAG HOLDERS

- **Sturdiness** : very rigid bag support consisting of a 4 mm flat bar plus elastic strap bag fixing system.
- **Easy use** : thanks to the wheels Ø 150 mm for easy movement.
- **Easy access** from the rear.

Central pre-sorting units	Overall dim. L x W x h (mm)	Ref.
Pre-sorting unit with 2 bag holders	1262 × 600 × 900	<u>707 535</u>
Pre-sorting unit with 3 bag holders	1750 × 600 × 900	<u>707 536</u>
Pre-sorting unit with 4 bag holders	2355 × 600 × 900	<u>707 549</u>
Pre-sorting unit on wheels with 2 bag holders	1262 × 600 × 900	<u>717 535</u>
Pre-sorting unit on wheels with 3 bag holders	1750 × 600 × 900	<u>717 536</u>
Pre-sorting unit on wheels with 4 bag holders	2355 × 600 × 900	<u>717 549</u>
Additional bag holder height 800 mm		<u>804 460</u>

## Options

Drop down and lift up rest on stainless steel consoles, the linear meter - Ref. 703497

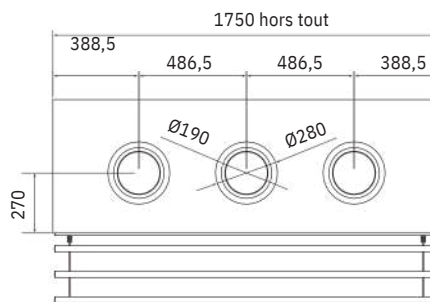
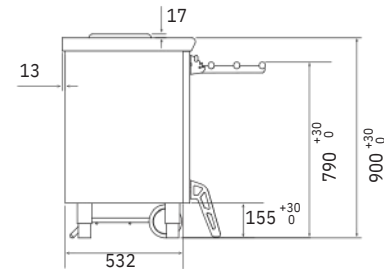
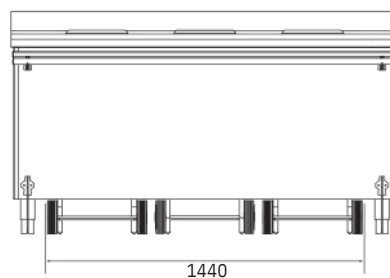

Quotations	A	B	C
Sorting unit for "children"	720	610	398
Sorting unit for "children"	900	790	578



717 549

# WALL PRE-SORTING UNITS FOR CHILDREN

Units to be placed against a wall. Without rear cladding (for the same cladding, see option ref. 702 053. Right rear upstand 100 mm high. Delivered without bag holder. The furniture is supplied with a lifting/folding ramp on stainless steel consoles to facilitate access to the bag holders. Safety stand to avoid any risk of the cabinet tipping over with a narrow base.

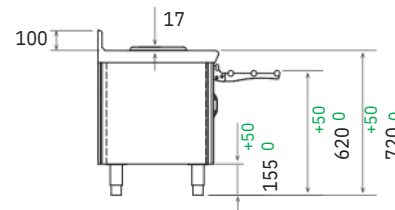
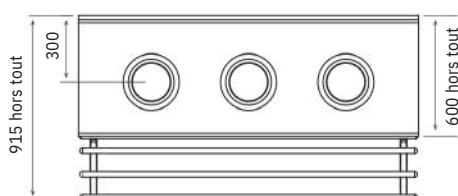
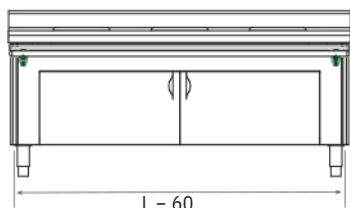

### Ergonomic :

Tray rail and waste disposal holes adapted to the right height for children.

Wall pre-sorting units CHILDREN	Overall dim. L x W x h (mm)	Ref.
Unit with 2 waste outlet	1262 x 600 x 720	707 565
Unit with 3 waste outlet	1750 x 600 x 720	707 566
Unit with 4 waste outlet	2355 x 600 x 720	707 567
Unit on wheels with 2 waste outlet	1262 x 600 x 720	717 565
Unit on wheels with 3 waste outlet	1750 x 600 x 720	717 566
Unit on wheels with 4 waste outlet	2355 x 600 x 720	717 567



707 566



707 567



717 565



# WALL PRE-SORTING UNITS FOR ADULTS



Units to be placed against a wall. Without rear cladding (for the same cladding, see option ref. 702 053). Right rear upstand 100 mm high. Delivered with bag holder 600 mm high without lid, arranged behind the 2 hinged doors under the tray rest (4 doors for unit with 4 empty waste hole). The unit is supplied with a lifting / and folding ramp on stainless steel consoles to facilitate access to the bag holder. Safety stand to avoid any risk of the cabinet tipping over with a narrow base.

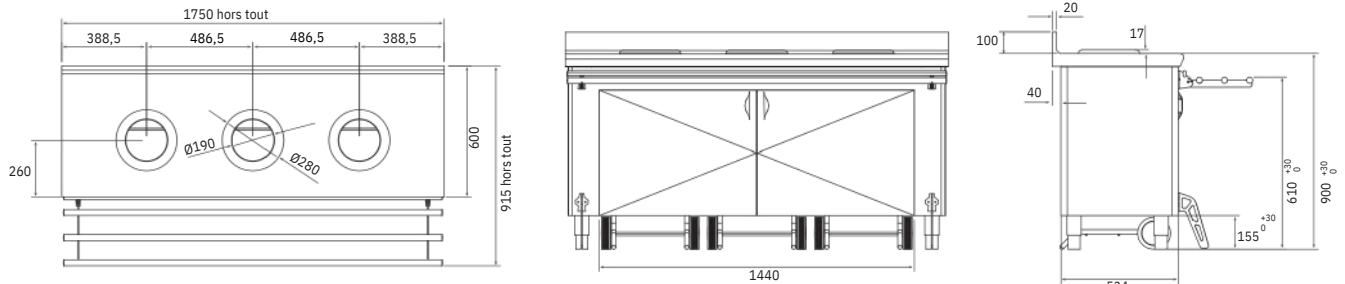

Wall pre-sorting units ADULTS	Overall dim. L x w x h (mm)	Ref.
Unit with 2 waste outlet and 2 bag holder	1262 × 600 × 900	<u>707 542</u>
Unit with 3 waste outlet and 3 bag holder	1750 × 600 × 900	<u>707 543</u>
Unit with 4 waste outlet and 4 bag holder	2355 × 600 × 900	<u>707 544</u>
Unit with 2 waste outlet and 2 bag holder on wheels	 1262 × 600 × 900	<u>717 542</u>
Unit with 3 waste outlet and 3 bag holder on wheels	 1750 × 600 × 900	<u>717 543</u>
Unit with 4 waste outlet and 4 bag holder on wheels	 2355 × 600 × 900	<u>717 544</u>
Additional bag holder height 620 mm		<u>804 471</u>



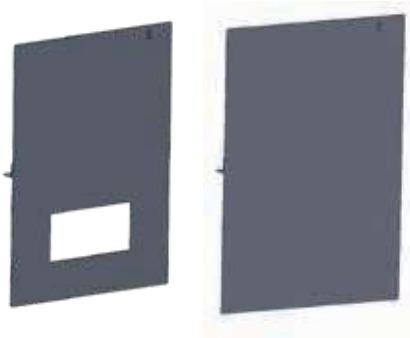

507 562

507 563

## Information plates

Format : 210 × 297 mm

Description	Référence
<b>Pre-sorting units with weighing</b>	
Magnetic stainless steel plate for waste disposal hole with weighing	<u>507 562</u>
Magnetic stainless steel plate for waste disposal hole without weighing	<u>507 563</u>
<b>For the other sorting and pre-sorting units</b>	
Hook-on stainless steel plate for units placed against a wall, per unit	<u>507 561</u>



507 561

507 561

## Stickers

Description	Reference
Food waste sticker	<u>221 650 G</u>
Plastic - metal sticker	<u>221 650 J</u>
Bread sticker	<u>221 650 M</u>
Glass sticker	<u>221 650 V</u>
Paper - Cardboard sticker	<u>221 650 B</u>
Sticker for personalised information	<u>221 650 P</u>



221 650G



221 650J

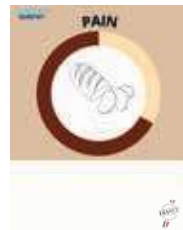

221 650M



221 650V



221 650B



221 650P

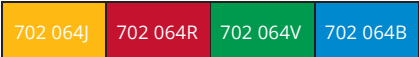

## Surrounds

Description	Reference
<b>Replacement when ordering a grey rubber surround for a coloured surround :</b>	
• Extra for yellow rubber surround	702 064 J
• Extra for red rubber surround	702 064 R
• Extra for green rubber surround	702 064 V
• Extra for blue rubber surround	702 064 B



507 840

507 841



507 842

<b>Pre-sorting units with weighing :</b>	
<b>Replacement when ordering a stainless steel surround for a grey surround</b>	
Extra cross shaped stainless steel surround	<u>507 840</u>
Extra rectangular shaped stainless steel surround	<u>507 841</u>
Extra hexagonal shaped stainless steel surround	<u>507 842</u>



## Cladding

Description	Reference
Extra for cladding of units in other Eurodekor shades, per linear metre (1)	703 503
Extra for laminate rear cladding of wall-mounted sorting units and pre-sorting units, per unit	702 053
Extra for stainless steel rear cladding of wall-mounted sorting units and pre-sorting units, per unit	702 058

(1) For lengths, < 1 m, take the price per for 1 m



## Rail

Description	Reference
Lift-up and fold-away tray rail for central pre-sorting unit, per linear metre (1)	703 497
Reduction for ramp not supplied, per linear metre (1)	703 495

(1) For lengths < 1 m, take the price per for 1 m



Bag holder

## Miscellaneous

Description	Reference
Extra bag holder, 800 mm high for central pre-sorting units and pre-sorting tables	<u>804 460</u>
Extra bag holder, 620 mm high for wall-mounted pre-sorting units for adults	<u>804 471</u>
Removable bag to be fitted on bag holder structure	<u>118 845</u>
Labels for sorting waste 5 colours	<u>296 298</u>
Extra/reduction for addition/removal of waste disposal hole, per unit (1)	701 102
Extra/reduction for addition/removal of recess for racks (1)	702 042
Extra/reduction for addition/removal of cut-out for 3 containers (1)	702 062

(1) Grey rubber as standard.



Removable bag to be fitted on bag holder structure